

# RAPTOR Series



Operating and Maintenance Instructions  
For RAPTOR Series Pneumatic Torque Wrenches



1025 Conroy Place, Easton PA 18040  
Phone: 610-250-5800 \* Fax: 610-250-2700  
Toll-Free: 1-888-TORCUP-1  
E-mail: [sales@torcup.com](mailto:sales@torcup.com) \* Website: [www.torcup.com](http://www.torcup.com)



**OPERATION and MAINTENANCE MANUAL  
FOR TorcUP RAPTOR 500, RAPTOR 1000,  
RAPTOR 2000, RAPTOR 3000 and RAPTOR 6000  
SQUARE DRIVE PNEUMATIC TORQUE WRENCHES**

**NOTICE**

Series RAPTOR 500, RAPTOR 1000, RAPTOR 2000, RAPTOR 3000 and RAPTOR 6000 Pneumatic Torque Wrenches are designed for installing and removing thread fasteners requiring precise high torque during bolt makeup and maximum torque for bolt breakdown.

TorcUP Inc. is not responsible for customer modification of tools for applications on which TorcUP Inc. was not consulted.

**WARNING**

**IMPORTANT SAFETY INFORMATION ENCLOSED.  
READ THIS MANUAL BEFORE OPERATING TOOL.  
IT IS THE RESPONSIBILITY OF THE EMPLOYER TO PLACE THE INFORMATION IN THIS  
MANUAL INTO THE HANDS OF THE OPERATOR.  
FAILURE TO OBSERVE THE FOLLOWING WARNINGS COULD RESULT IN INJURY.**

**The Raptor tools contain alloy components which may  
cause a hazard in certain explosive environments.**

**General Description of TorcUP RAPTOR Series  
Pneumatic Torque Wrenches**

Torque can be adjusted by regulating the amount of airflow to the torque wrench and by manipulating the air pressure regulating valve at the Filter/Regulator/Lubricator Unit (RAPTOR F/R/L). On top, an airflow volume control is incorporated at the machine providing an extended torque range. The accuracy of maintaining a selected torque is subject to the stability of your air supply. An airflow of 25 to 40 SCFM guarantees optimum performance even within a non-protected working environment.

The RAPTOR Series Pneumatic Torque Wrench provides torque settings of up to 6,000 Ft. Lbs, clockwise and counter clockwise rotation, random positioning of the tool due to its free joint execution.

**NOTICE**

**The use of other than genuine TorcUP replacement parts may result in safety hazards, decreased tool performance, and increased maintenance, and may invalidate all warranties.**

**Repairs should be made only by authorized personnel. Consult your nearest TorcUP Authorized Service center.**

**Refer All Communications to the Nearest TorcUP Office or Distributor.**

*TorcUP Inc.*

**For Technical Support and Information Contact:**

**TorcUP, Inc.  
1025 Conroy Place  
Easton, PA 18040  
Toll Free: (888) TORCUP-1  
Fax: (610) 250-2700  
E-mail: [info@torcup.com](mailto:info@torcup.com)**

## WARNING

### FAILURE TO OBSERVE THE FOLLOWING WARNINGS COULD RESULT IN INJURY

#### USING THE TOOL

- Keep hands, loose clothing and long hair away from the reaction arm and working area during operation.
- This tool will exert a strong reaction force. Use proper mechanical support and correct reaction arm positioning to control these forces. Do not position the reaction arm so that it tilts the tool off the axis of the bolt and never use the swivel inlets as a reaction stop.
- Avoid sharp bends and kinks that will cause severe back-up pressure in hoses and lead to premature hose failure.
- Use accessories recommended by TorcUP.
- Use only impact sockets and accessories. Do not use hand (chrome) sockets or accessories.
- Use only sockets and accessories that correctly fit the bolt or nut and function without tilting the tool off the axis of the bolt.
- This tool is not insulated against electric shock.
- This equipment must not be operated or serviced unless the operator read the operating instructions and fully understands the purpose, consequences and procedure of each step

Always turn off the air and disconnect the fitting before installing, removing, or adjusting any accessory on this tool, or before performing any maintenance on this tool.



Do NOT exceed Maximum Pressure. See Torque Chart. Damage May Occur.

Always wear ear protection when operating this tool.



The Torque Reaction Arm must be positioned against a positive stop. Do not use the Arm as a dead handle. Take all precautions to make certain the operator's hand cannot be pinched between the Arm and a solid object.

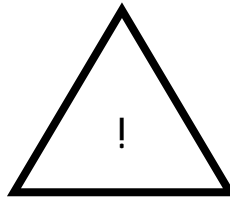

Always wear eye protection when operating or performing maintenance on this tool.



Keep body stance balanced and firm. Do not overreach when operating this tool.



Do not carry the tool by the hose.



Do not use damaged, frayed or deteriorated air/pneumatic hoses and fittings.



## WARNING

### Operation of the Equipment in Accordance with Specified Use

Depending on the working environment and how the RAPTOR Series Pneumatic Torque Wrench is used, local health and safety regulations may require you protective gear (i.e. Ear Protection, Safety Shoes, Hard Hat, Gloves, Coveralls, etc.) In case external forces are exerted on the equipment, non-compliance with these regulations may result in injury. EAR PROTECTION MUST BE WORN WHEN OPERATING THIS TOOL. When in continuous use the grip casing will cool down considerably – operator should wear protective-working gloves as a consequence.

## Operation of the Equipment in Accordance with Specified Use – Con't

1. Inspect, maintain, operate and install the tool in accordance with all applicable standards and regulations (local, state, country, federal, etc.)
2. Do not remove any labels. Replace any damaged labels immediately.
3. Always use clean, dry air at 90 p.s.i.g. (6.2 bar/620kPa) maximum air pressure at the inlet. Higher pressure may result in hazardous situations including excessive speed, rupture, or incorrect output torque or force.
4. Be sure all hoses and fittings are the correct size and tightly secured.
5. Ensure an accessible emergency shut off valve has been installed in the air supply line, and make others aware of its location.
6. Install a properly sized safety air fuse upstream of hose and use an anti-whip device across any hose coupling without internal shut-off, to prevent hose whipping if a hose fails or coupling disconnects.
7. Do not use damaged, frayed or deteriorated air hoses and fittings. Do not paint hoses.
8. Keep clear of whipping air hoses. Shut off the air compressor before approaching a whipping hose.
9. Always turn off the air supply, bleed the air pressure and disconnect the air supply hose before installing, removing or adjusting any accessory on this tool, or before performing any maintenance on this tool or any accessory.
10. Do not lubricate tools with flammable or volatile liquids such as kerosene, diesel or jet fuel. Use only TorcUP recommended lubricants.
11. Use only proper cleaning solvents to clean parts. Use only cleaning solvents which meet current safety and health standards. Use cleaning solvents in a well ventilated area.
12. Keep work area clean, uncluttered, ventilated and illuminated.

## Safety Information When Using The Tool

1. When wearing gloves always be sure that the gloves will not prevent the throttle mechanism from being released.
2. Always wear eye protection when operating or performing maintenance on this tool.
3. Always wear hearing protection when operating this tool.
4. Always use Personal Protective Equipment appropriate to the tool used and material worked. This may include dust mask or other breathing apparatus, safety glasses, ear plugs, gloves, apron, safety shoes, hard hat and other equipment.
5. Prevent exposure and breathing of harmful dust and particles created by the tool use.
  - a. Some dust created by power sanding, sawing, grinding, drilling, and other construction activities contains chemicals known to cause cancer, birth defects or other reproductive harm. Some examples of these chemicals are:
    - i. Lead from based paints
    - ii. Crystalline silica from bricks and cement and other masonry products
    - iii. Arsenic and chromium from chemically treated lumberYour risk from these exposures varies, depending on how often you do this type of work. To reduce your exposure to these chemicals: work in a well ventilated area, and work with approved safety equipment, such as dust masks that are specially designed to filter out microscopic particles.
6. Keep others a safe distance from your work area, or ensure they use appropriate Personal Protective Equipment.
7. Be aware of buried, hidden or other hazards in your work environment. Do not contact or damage cords, conduits, pipes, or hoses that may contain electrical wires, explosive gases or harmful liquids.
8. Keep hands, loose clothing, long hair and jewelry away from working end of tool.
9. Power tools can vibrate in use. Vibration, repetitive motions or uncomfortable positions may be harmful to your hands and arms. Stop using any tool if discomfort, tingling feeling or pain occurs. Seek medical advice before resuming.
10. Keep body stance balanced and firm. Do not overreach when operating this tool. Anticipate and be alert for sudden changes in motion, reaction torques, or forces during start up and operation.
11. **DO NOT USE THIS TOOL WHEN TIRED, UNDER THE INFLUENCE OF MEDICATION, DRUGS OR ALCOHOL.**
12. Never use a damaged or malfunctioning tool or accessory.
13. Do not modify the tools, safety devices or accessories.
14. Do not use this tool for purposes other than those recommended.
15. Never exceed rated RPM of tool.

## PLACING THE TOOL IN SERVICE

1. Must ensure air line is not connected to tool before following the following steps.
2. Ensure the reaction arm is properly attached and secured to splined section on the torque tool.
3. Select your desired square drive size and bolt/nut AF size impact socket or hex-drive socket for use.
4. Secure impact socket on tool square drive with lock pin and securing safety BUNA-N (NITRILE) O-ring on socket.
5. Use a quality Filter/Lubricator/Regulator Unit that meets airflow requirements or use

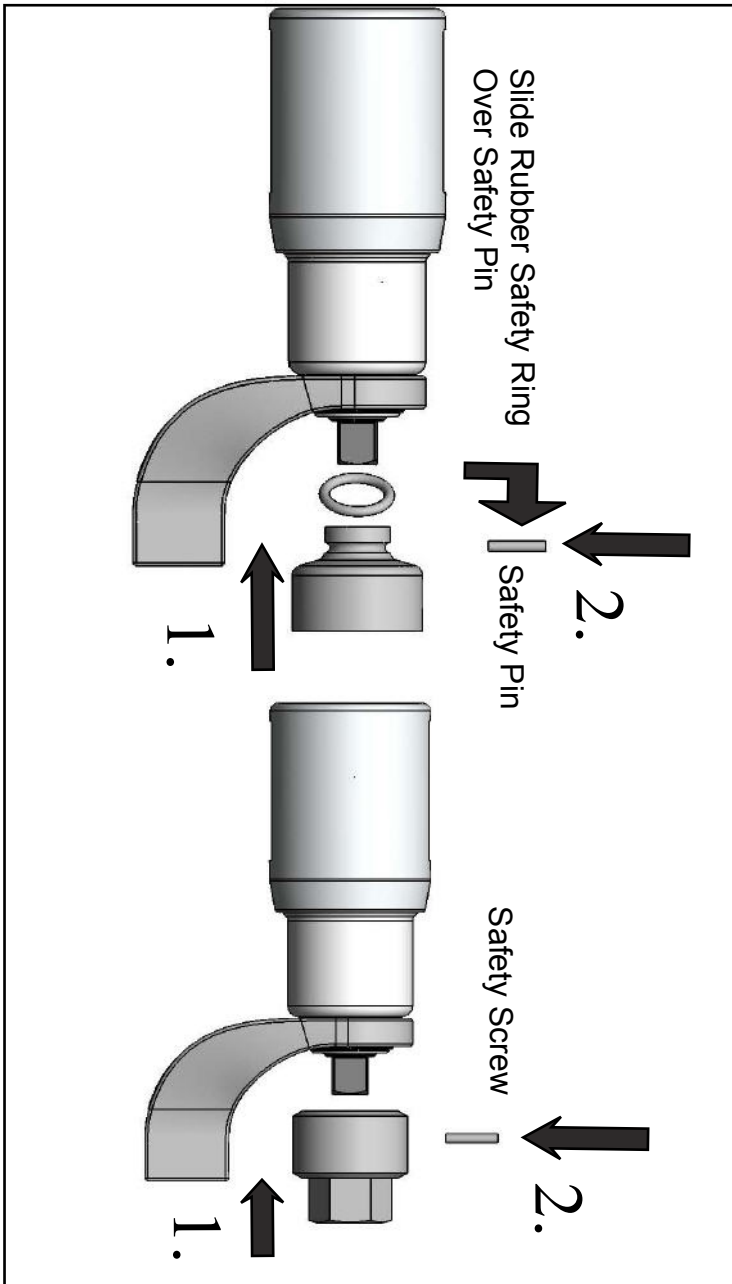
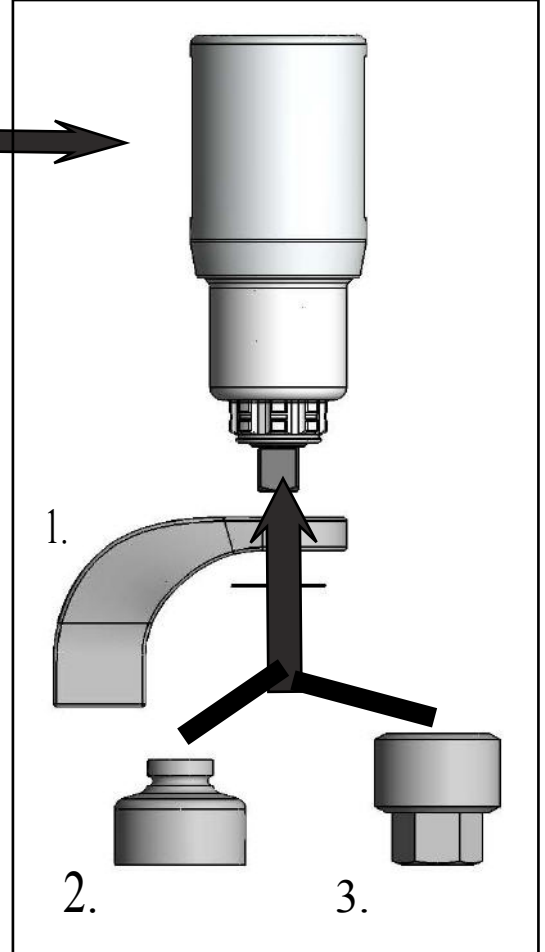
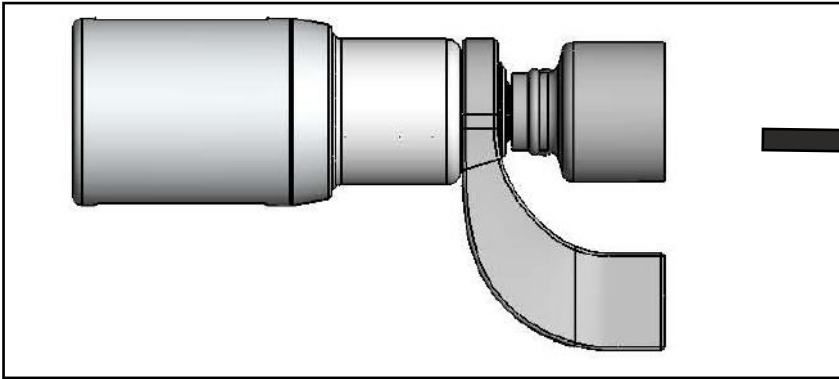

### IMPORTANT

For A Long Life of the Air Motor;

USE Quality F/R/L Unit

Must Meet Airflow Requirements

Lubricator Provides Oil  
To Air Motor

Filter Separates Water To  
Extend Life To Motor Vanes

An Air Pressure Regulator To  
Accurately Set Torque Settings

## OPERATING PROCEDURES

### Setting Torque on RAPTOR Series Torque Wrenches

1. Torque depends on the air pressure exerted on the air motor under load. Adjusting the F/R/L Unit Regulator Knob initially sets torque. To decrease torque output turn regulator counter-clockwise to lower air flow/pressure. All Raptors are shipped calibrated per TorcUP Procedures.

2. Check for Desired Torque Setting for your selected model on the supplied torque chart. On the RAPTOR F/R/L, adjust air pressure by using the air regulator knob for desired pressure/torque. With the RAPTOR Series Torque Wrench under load (not on the nut/bolt), press the toggle switch. Once pressure is set for desired torque output and airflow/pressure, push in on regulator knob to lock unit. While the RAPTOR Series Torque Wrench is under load, running at free speed (not on the nut/bolt), adjust the RAPTOR F/R/L pressure at the same time.

#### A. Setting torque for Bolt Tightening

1. Establish the air pressure required using the Torque Calibrated Chart. Provided with the tool.
2. Push Trigger using tightening Direction per A on below diagram.
3. Adjust the regulator until the correct pressure is shown on the gauge by turning adjustment knob clockwise.

#### B. Setting torque for Bolt Loosening

1. Establish maximum air pressure from the Torque Chart.
2. Push Trigger using loosening Direction per B on below diagram.
3. Set the air pressure the same as with tightening.

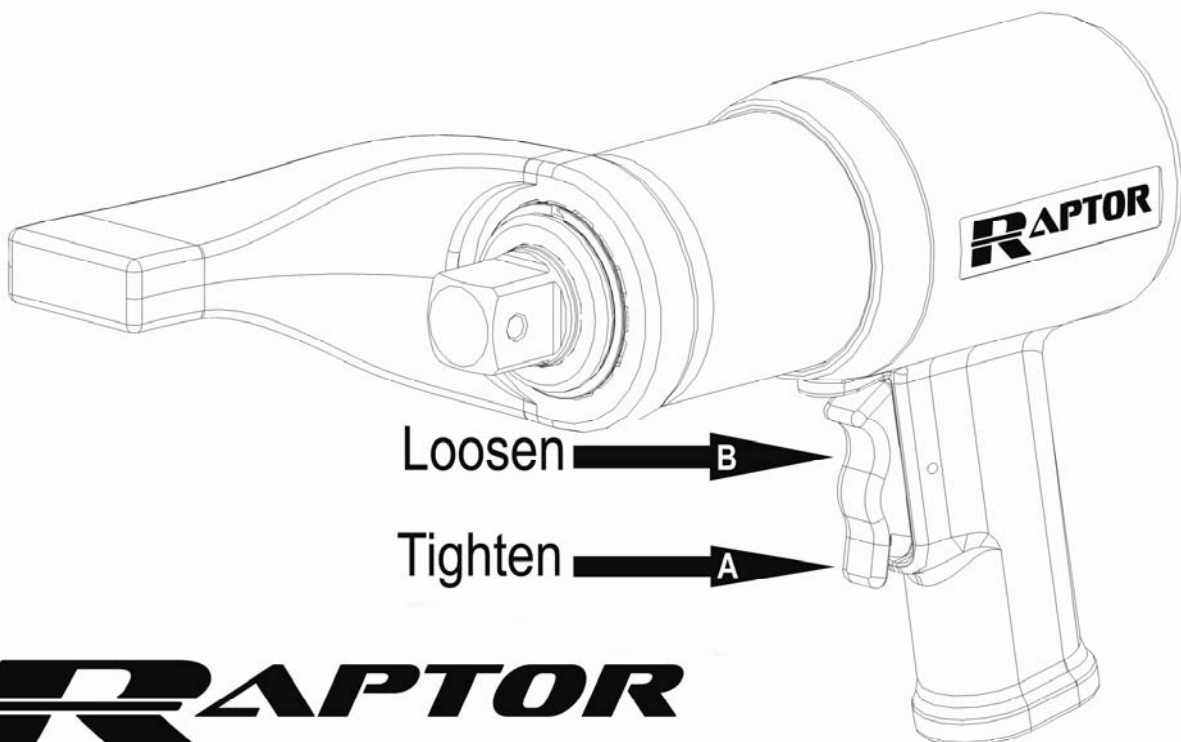

# RAPTOR

## NOTICE

After extended use of the RAPTOR Series Torque Wrench, Air Pressure Setting should be rechecked and may require minor adjustment. This is usually caused by variations in your air supply unit providing your airflow to F/R/L Unit or due to weather conditions.

## WARNING

Within the very first hours of operation a slight amount of grease may leak through the equipment casing. In this case remove excess to avoid risk of slipping while running the equipment or – for some specific applications – environmental pollution.

## IMPORTANT

In case of degrading performance or other apparent damage immediately send your RAPTOR Series Torque Wrench to TorcUP, Inc or contact your Local Representative or Distributor. Unit must be properly packaged for shipping.

## Operating Procedures

### IMPORTANT

**Unauthorized manipulation of air motor, valves, & TorcUP F/R/L Unit or tampering with either will result in loss of warranty! Also for the life of your TorcUP RAPTOR Series Torque Wrench air supply should be clean and free of particles, water and other remains. Pollution of hose couplings or aggressive substances reaching air motor via the supply hose may cause damage to air motor vanes. Use approved F/R/L Units to obtained oil-enriched and filtered supply. Non-compliance with the specified operating air pressure will result in higher wear of the motor. Degradation in performance is likely to result. Also for extreme cold weather use approved cold weather pneumatic lubrication to prevent freeze ups.**

### WARNING

***Beware of low-pressure air components. Do not fold or bend the supply hose excessively and check for damage before use. A damaged hose must not be used, as there is a risk of a hose burst. This may lead to a wildly lashing hose with a risk of personal injury. Also check air fitting and connections tightness or damage.***

## Tightening and Loosening of Bolts or Nuts

### WARNING

- *Beware of non-fixed freely rotating Reaction Arms or of rotating Impact Sockets.*
- *Loose clothes, long hair, cables, etc. are always to be kept away from danger/rotation area. When the machine is put into operation wearing ear protection, safety shoes and safety goggles is mandatory.*
- *Never leave a running RAPTOR Series Torque Wrench unattended and always be ready to switch off the machine if necessary. Maintain a safety distance of arm length.*
- *Always place the impact socket or hex driver snugly on screw or nut/bolt. Faulty screw or nut/bolt connections may result in exceeding the mechanical stress limit of the material, causing it to break. Parts splintering off may cause bruises or even life-threatening injuries.*
- *Due to emission of an air-oil mixture, a breathing mask must be worn, especially when working over the head and in tight, secluded spaces.*

During torquing and untorquing fasteners, always hold/position the RAPTOR Series Torque Wrench perpendicular to fastener axis (in line with the fastener axis...or perpendicular to the nut/bolt head), since either the impact socket or hex driver and the nut/bolt to be worked on may be deformed or damaged otherwise. Furthermore a safe counter reaction point may not be achieved or cannot be guaranteed any longer. See Illustration on following page.

### NOTICE

The indicated calibrated torque settings have to be considered only as a guideline. Because of variations in pressure and or mass flow of supply air as well as different screwing applications (soft/hard) deviations from the normative setting may occur. Due to the CFM required when the tool is running at Free Speed, it may not be possible to set the regulator to the desired pressure due to air pressure drop off. The CFM requirement is lower once the tool is under load, so if this happens, set the regulator to the desired PSI without the tool running. Try tightening down the fastener and check the PSI when the tool stalls. If the tool stalls at the PSI setting, the desired torque has been reached. If it has stalled before, try adjusting regulator higher until the correct stall PSI is reached.

## CAUTION

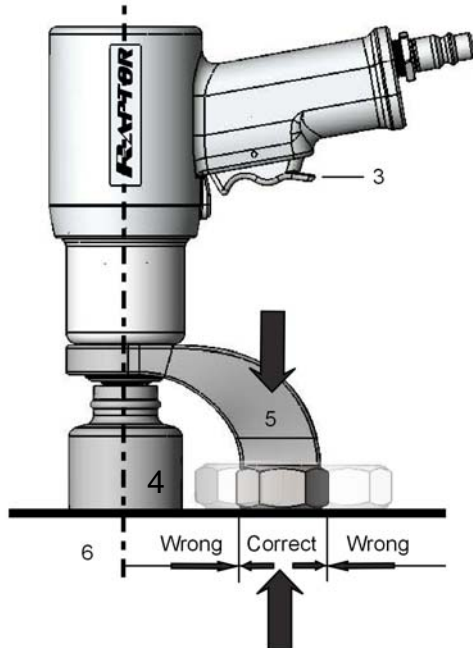

Safe support only within the indicated area

Because of the high mechanical stress on the RAPTOR Series air motor it is essential to provide the F/R/L Unit with sufficient oil supply. Non-compliance bears risk of damaging the vanes of the air motor. Enriching the supply by adjusting the oil feed on F/R/L to 2 to 3 drops per minute will suffice for heavy continuous equipment use.

1. Place your RAPTOR Series Torque wrench completely over and on the fastener to be tightened or loosened. (4)
2. Ensure the reaction area / moment is taken up by the Reaction Arm (5). Also ensure reaction is stable and will support counter torque.
3. Hold RAPTOR Series Torque Wrench perpendicular to fastener axis (6) for the complete duration of rotation process for tightening or loosening.
4. After activating the Toggle Switch (3) on the pistol grip, when tightening the fastener the Tool will rotate until it becomes torqued and the RAPTOR Series Torque Wrench will then stall out.
5. The Toggle will then need to be depressed in the opposite direction for opposite tool rotation to release counter torque load off the reaction arm. Once this done, you then can remove and move to your next fastener.
6. For loosening a fastener, the unit will continue to rotate until the fastener is removed or when fastener is loose by hand you can stop move to next fastener.
7. Continue the process for tightening or loosening for each fastener you require.
8. If torque requirements require your application to go in torque increments. Then set RAPTOR Series Torque Wrench to your first torque requirement. Tighten fastener as per your required tightening bolt sequence. Then reset for next settings on F/R/L unit by adjusting Regulating Knob as described earlier.
9. Your personnel can be trained by your TorcUP Representative or Distributor on use of this product if so desired.

## Changing Accessories on the RAPTOR Series Torque Wrench

1. Remove RAPTOR Series from work and back off the regulator knob to decrease the pressure to zero while depressing toggle switch.
2. Disconnect the air hose to the RAPTOR Series Torque Wrench.
3. Remove and change socket or accessory adaptor for next project. Insure socket or accessory is properly secured to square drive with locking pin and safety securing BUNA-N (NITRILE) o-ring.

## WARNING

***Beware of components under pressure. Inadvertent activation of the torque wrench may lead to both a risk of injury as well as damage to property. When detaching the supply air hose always shut off air to supply first. Non-compliance with procedure may result in an out-of-control supply hose thus risking injury personal injury and damage to property.***

### Storing Your RAPTOR Series Torque Wrench

1. Shut off pressurized air to the F/R/L by turning off the air to F/R/L Unit.
2. Bleed off air by depressing toggle switch either direction on the Pistol Grip.
3. Disconnect Supply Hose to F/R/L and Disconnect air hose at RAPTOR Series
4. If the RAPTOR Series Torque Wrench is not to be used for an extended period of time, spray pneumatic lubricating oil into RAPTOR Series Fitting. Reconnect air hose and supply to F/R/L Unit Air Inlet Fitting. Cycle the RAPTOR Series Unit momentarily to ensure good quality amount of lubricating has entered into air motor. Then stop and shut-off the system as previously mentioned above and store your RAPTOR Series Torque Wrench in the case that it was shipped in.

### Technical Data

Model Number	RAPTOR 500	RAPTOR 1000	RAPTOR 2000	RAPTOR 3000	RAPTOR 6000
Square drive	3/4"	3/4"	1"	1"	1 1/2"
Min. Torque (Ft/Lbs)	120	250	450	740	1000
Max. Torque (Ft/Lbs)	500	1000	2000	3000	6000
Min. Torque (Nm)	162	338	610	1003	1356
Max. Torque (Nm)	677	1355	2711	4067	8134
Diameter A (in)	7.86"	7.86"	7.86"	7.89"	8.16"
Diameter A (mm)	199.65	199.65	199.65	200.41	207.26
Diameter B (in)	0.75"	0.75"	1.00"	1.00"	1.50"
Diameter B (mm)	19.05	19.05	19.05	19.05	38.1
Diameter C (in)	6.82"	7.78"	8.35"	9.99"	12.35"
Diameter C (mm)	170.5	197.62	211.33	253.75	313.69
Diameter D (in)	2.56"	2.62"	2.85"	3.44"	4.00"
Diameter D (mm)	65.03	66.55	72.39	87.38	101.6
Weight (Lbs)	9	10	12	16	20
Weight (Kg)	4	4.5	5.4	7.3	9.07
Performance (RPM)	45	25	20	5	2.5

RAPTOR

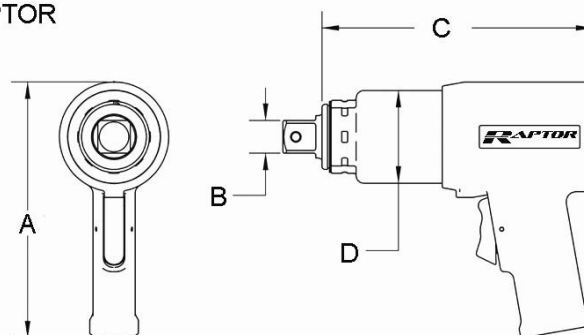

## RAPTOR Series Pneumatic Torque Wrench Torque Charts

Air Reg. PSI	RAPTOR 500	RAPTOR 1000	RAPTOR 2000	RAPTOR 3000	RAPTOR 6000
10					
20					
30					
40					
50					
60					
70					
80					
90					
100					

Please consult the calibration torque chart specific to your purchase or rental tool. Do NOT exceed maximum pressure. See Torque Chart. Tool Damage may occur.

## Noise and Vibrations

Sound pressure level, measured in accordance OSHA & German Machinery-Noise-Information-Leaflet-3-GSGV requirements dated 18 Jan 1991, §1, (1 e) at maximum equipment performance is just over 85 dB(A).

In accordance with §1, (2) of the same leaflet sound pressure levels were measured for different work cycles, with the sensor at a distance of 1 meter to the geometric center of the machine. Vibrations become moderate just prior reaching the pre-set torque value.

On request RAPTOR Series Pneumatic Torque Wrenches with lower sound pressure levels (<85 dB(A)) are available as special modification. Because this modification comprises a sound absorber, relevant torque values may change on given unit.

### NOTICE

SAVE THESE INSTRUCTIONS. DO NOT DESTROY.

# Raptor 500

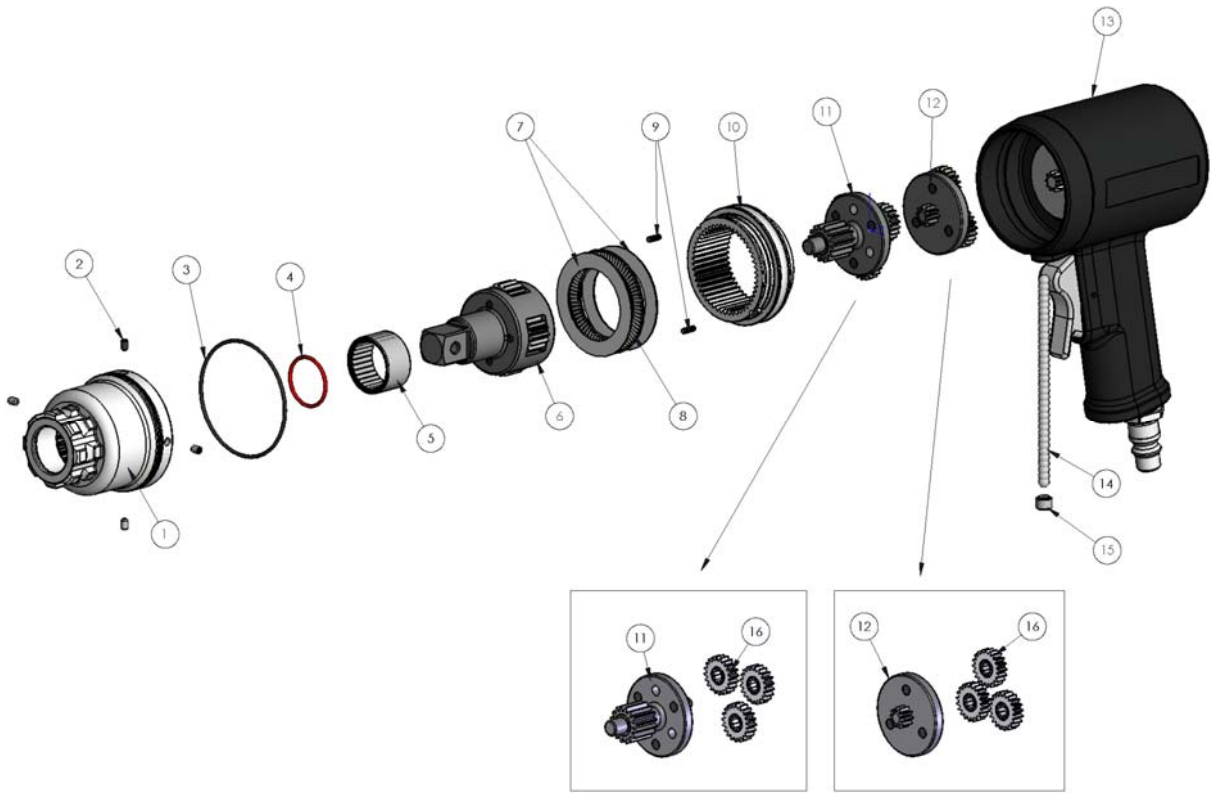

ITEM	QTY.	Part #	DESCRIPTION
1	1	RP-05-P0-01-OM	Drive Annulus
2	4	RP-CM-10/32x.25	10-32 x 3/8 SET SCREW
3	1	RP-CM-OR-039	Main Annulus O-Ring
4	1	RP-CM-OR-024	Drive O-Ring
5	1	RP-CM-BR-B1812	Main Bearing 1.125" ID x 1.375 OD x .750" LG
6	1	RP-05-P0-00-OA	Drive Stage Assembly
7	2	RP-CM-TRA2840	Thrust Washer 1.750" ID x 2.500" OD x .031" TK
8	1	RP-CM-NTA2840	Needle Roller Bearing 1.750" ID x 2.500"OD x .0781" TK
9	2	RP-CM-DP-01.06	1/8" Dia x 3/8" Long Hardened Dowel
10	1	RP-20-P0-36-OM	High End Annulus
11	1	RP-05-P0-01-OA	2nd Stage Assembly
12	1	RP-20-P0-03-OA	1st Stage Assembly
13	1	RP-00-P0-02-OA	RP Handle and Motor Assembly
14	35	RP-CM-BB-04.G25	E52100 Alloy Steel Ball 1/4" Diameter, Grade 25
15	1	RP-00-P0-12-OM	RP - Air Motor Ball Retainer
16	6	RP-20-P0-38-OM	Spur Gear

# Raptor 1000

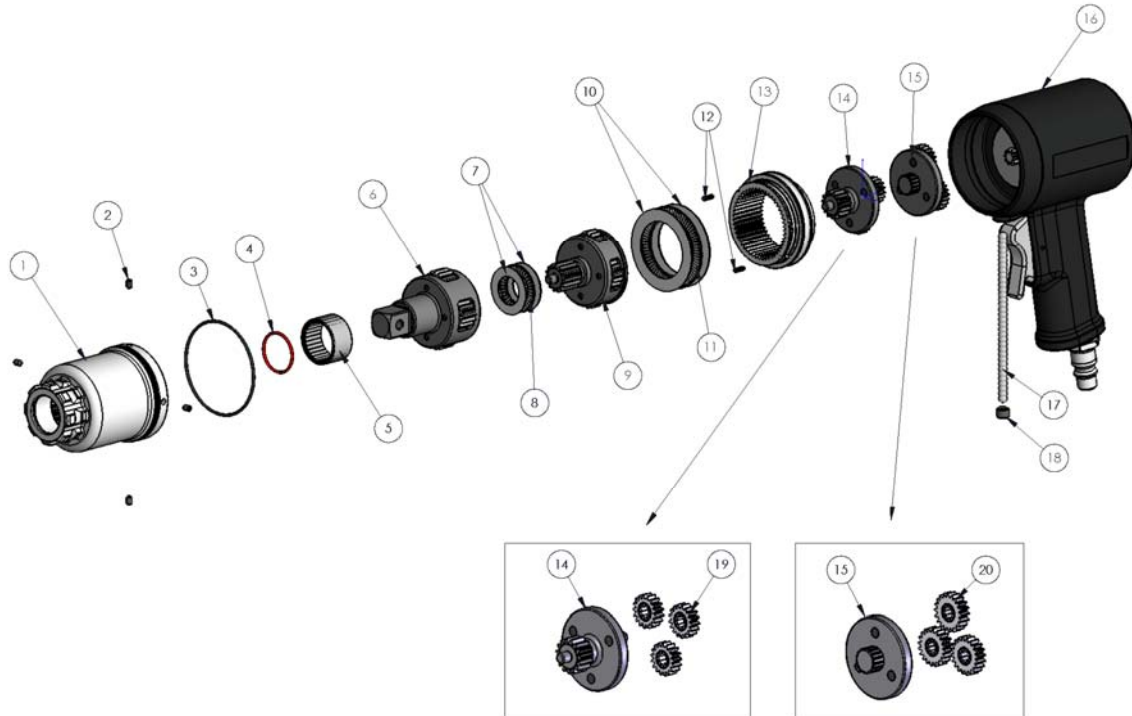

ITEM	QTY.	PART #	DESCRIPTION
1	1	RP-10-P0-06-OM	Drive Annulus
2	4	RP-CM-10/32x.37	10-32 x 3/8 SET SCREW
3	1	RP-CM-OR-039	Main Annulus O-Ring
4	1	RP-CM-OR-024	Drive O-Ring
5	1	RP-CM-BR-B1812	Main Bearing 1.125" ID x 1.375 OD x .750" LG
6	1	RP-10-P0-00-OA	Drive Stage Assembly
7	2	RP-CM-TRA1423	Thrust Washer .875" ID x 1.4375" OD x .032" TK
8	1	RP-CM-NTA1423	Needle Roller Bearing .875" ID x 1.4375" OD x .0781" TK
9	1	RP-10-P0-01-OA	3rd Stage Assembly
10	2	RP-CM-TRA2840	Thrust Washer 1.750" ID x 2.500" OD x .031" TK
11	1	RP-CM-NTA2840	Needle Roller Bearing 1.750" ID x 2.500" OD x .0781" TK
12	2	RP-CM-DP-01.06	1/8" Dia x 3/8" Long Hardened Dowel
13	1	RP-20-P0-36-OM	High End Annulus
14	1	RP-10-P0-02-OA	2nd Stage Assembly
15	1	RP-10-P0-03-OA	1st Stage Assembly
16	1	RP-00-P0-02-OA	RP Handle and Motor Assembly
17	35	RP-CM-BB-04.G25	E52100 Alloy Steel Ball 1/4" Diameter, Grade 25
18	1	RP-00-P0-12-OM	RP - Air Motor Ball Retainer
19	3	RP-00-P0-15-OM	Spur Gear
20	3	RP-20-P0-38-OM	Spur Gear

# Raptor 2000

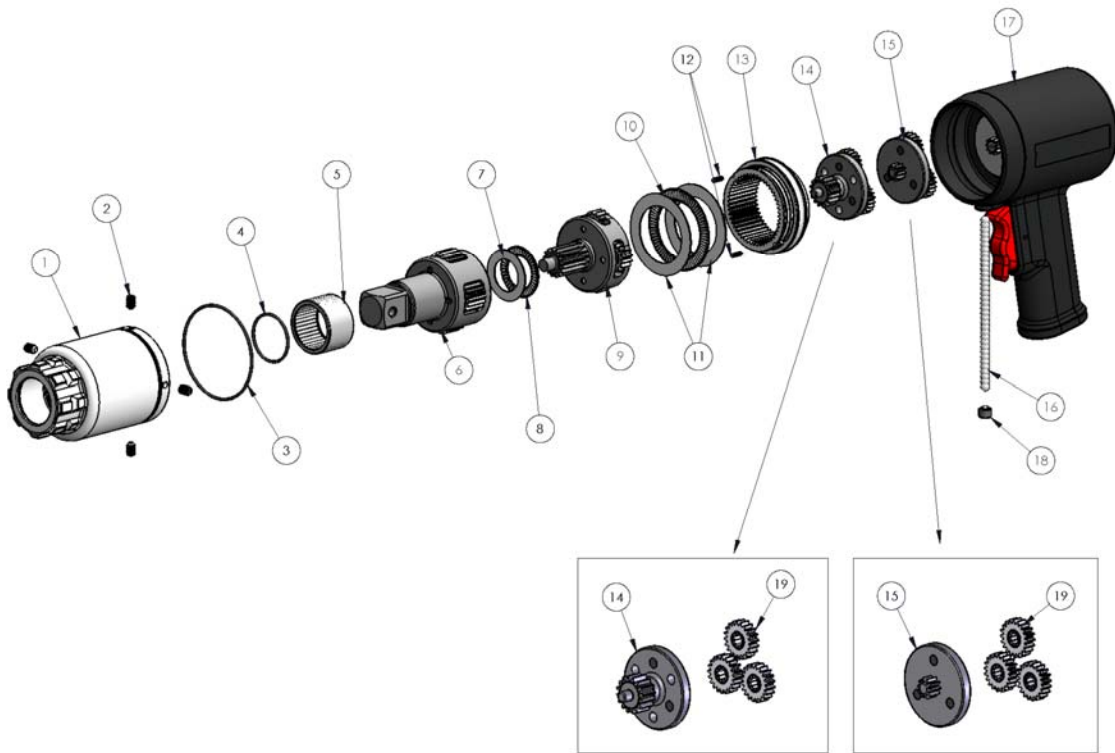

ITEM	QTY.	Part #	DESCRIPTION
1	1	RP-20-P0-62-OM	Drive Annulus
2	4	RP-CM-10/32x.25	10-32 x 1/4 SET SCREW
3	1	RP-CM-OR-039	Main Annulus O-Ring
4	1	RP-CM-OR-028	Drive O-Ring
5	1	RP-CM-BR-B2216	Main Bearing 1.375" ID x 1.625 OD x .750" LG
6	1	RP-20-P0-00-OA	Drive Stage Assembly
7	1	RP-CM-TRA1625	Thrust Washer 1.000" ID x 1.562" OD x .031" TK
8	1	RP-CM-NTA1625	Needle Roller Bearing 1.000" ID x 1.562" OD x .0781" TK
9	1	RP-20-P0-01-OA	3rd Stage Assembly
10	2	RP-CM-TRA2840	Thrust Washer 1.750" ID x 2.500" OD x .031" TK
11	1	RP-CM-NTA2840	Needle Roller Bearing 1.750" ID x 2.500" OD x .0781" TK
12	2	RP-CM-DP-01.06	1/8" Dia x 3/8" Long Hardened Dowel
13	1	RP-20-P0-36-OM	High End Annulus
14	1	RP-20-P0-02-OA	2nd Stage Assembly
15	1	RP-20-P0-03-OA	1st Stage Assembly
16	35	RP-CM-BB-04.G25	E52100 Alloy Steel Ball 1/4" Diameter, Grade 25
17	1	RP-00-P0-02-OA	RP Handle and Motor Assembly
18	1	RP-00-P0-12-OM	RP - Air Motor Ball Retainer
19	6	RP-20-P0-38-OM	Spur Gear

# Raptor 3000

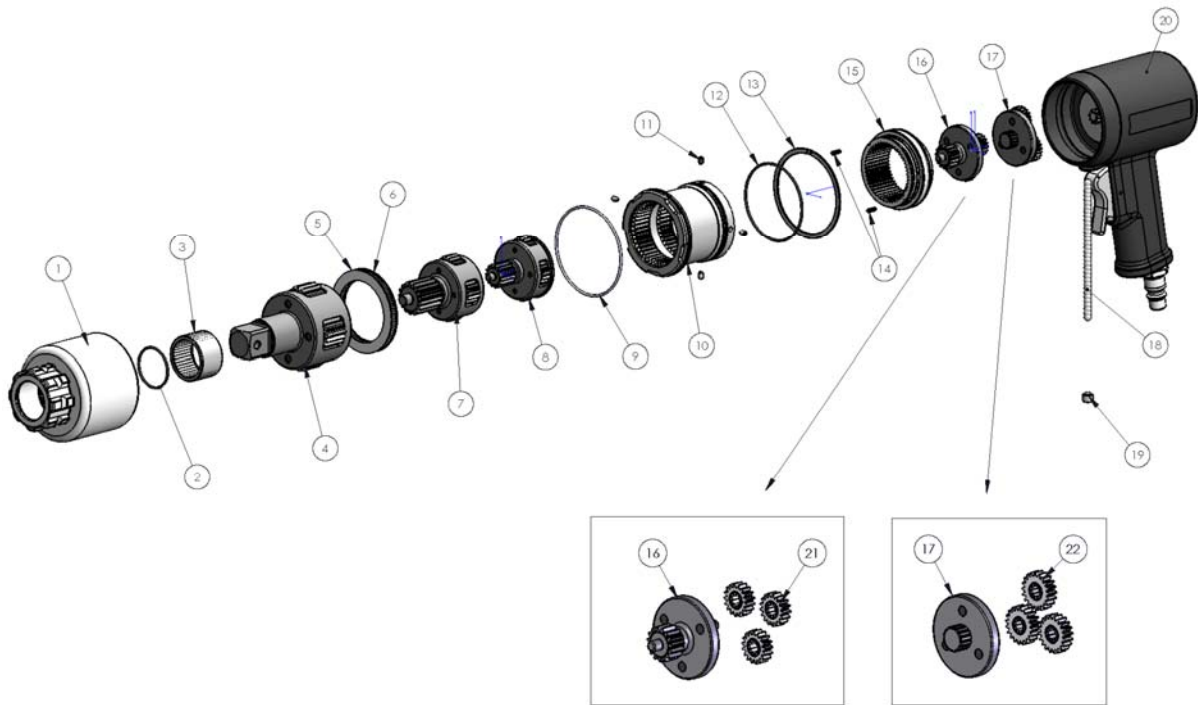

ITEM	QTY.	Part #	DESCRIPTION
1	1	RP-30-P0-01-OM	Drive Annulus
2	1	RP-CM-OR-028	Drive O-Ring
3	1	RP-CM-BR-B2216	Main Bearing 1.375" ID x 1.625 OD x .750" LG
4	1	RP-30-P0-00-OA	RP 3000 - Drive Stage Assembly
5	1	RP-CM-TRA3648	Thrust Washer 3.000" ID x 2.250" OD x .032" TK
6	1	RP-CM-NTA3648	Needle Roller Bearing 3.000" ID x 2.250" OD x .0781" TK
7	1	RP-30-P0-05-OA	4th Stage Assembly
8	1	RP-30-P0-01-OA	3rd Stage Assembly
9	1	RP-30-P0-20-OA	2nd Annulus
10	1	RP-CM-OR-042	Main Annulus O-Ring (AS 568A 2-042)
11	4	RP-CM-10/32x.37	10-32 x 3/8 SET SCREW
12	1	RP-CM-OR-039	Drive Annulus O-Ring
13	1	RP-30-SR-VH318	Main Annulus Retaining Ring (Smalley #: VH-318)
14	1	RP-CM-DP-02.06	High Strength Dowel Pin .125" Dia x .375" Long
15	1	RP-20-P0-36-OM	High End Annulus
16	1	RP-30-P0-04-OA	2nd Stage Assembly
17	1	RP-10-P0-03-OA	1st Stage Assembly
18	35	RP-CM-BB-04.G25	E52100 Alloy Steel Ball 1/4" Diameter, Grade 25
19	1	RP-00-P0-12-OM	RP - Air Motor Ball Retainer
20	1	RP-00-P0-02-OA	RP Handle and Motor Assembly
21	3	RP-00-P0-15-OM	Spur Gear
22	3	RP-20-P0-38-OM	Spur Gear

# Raptor 6000

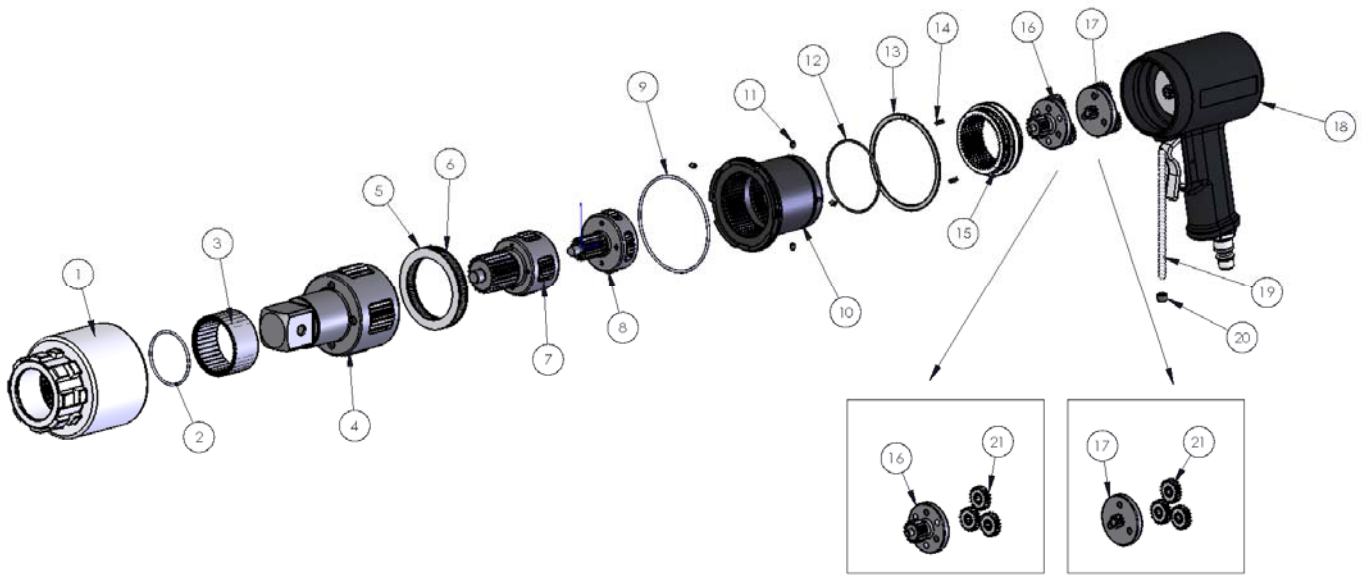

ITEM	QTY.	PART #	DESCRIPTION
1	1	RP-60-P0-01-OM	RP 6000 Drive Annulus
2	1	RP-CM-OR-033	Drive O-Ring
3	1	RP-CM-BR-B-3220	Main Bearing 2.000" ID x 2.375 OD x 1.250" LG
4	1	RP-60-P0-00-OA	RP 6000 Drive Stage Assembly
5	1	RP-CM-TRA-4052	Thrust Washer 3.250" OD x 2.500 ID x .0321" LG
6	1	RP-CM-NTA-4052	Needle Roller Bearing 3.250" OD x 2.500 ID x .0781" LG
7	1	RP-60-P0-05-OA	RP 6000 - 4th Stage Assembly
8	1	RP-20-P0-01-OA	RP 2000 - 3rd Stage Assembly
9	1	RP-CM-OR-044	6000 Drive Annulus O-Ring
10	1	RP-60-P0-20-OA	RP 6000 - 2nd Annulus
11	4	RP-CM-10/32x.37	10-32 x 1/4 SET SCREW
12	1	RP-CM-OR-038	Main Annulus O-Ring
13	1	RP-30-SR-WH368	Drive Annulus Retaining Ring (Smalley WH-368)
14	2	RP-CM-DP-01.06	1/8" Dia x 3/8" Long Hardened Dowel
15	1	RP-20-P0-36-OM	RP 2000 - High End Annulus
16	1	RP-20-P0-02-OA	RP 2000 - 2nd Stage Assembly
17	1	RP-20-P0-03-OA	RP 2000 - 1st Stage Assembly
18	35	RP-CM-BB-04.G25	E52100 Alloy Steel Ball 1/4" Diameter, Grade 25
19	1	RP-00-P0-02-OA	RP Handle and Motor Assembly
20	1	RP-00-P0-12-OM	RP - Air Motor Ball Retainer
21	6	RP-20-P0-38-OM	Spur Gear



## [MSDS for the Ingersol Rand Oil](#)

### **MATERIAL SAFETY DATA SHEET FOR INGERSON RAND OIL**

10Z4, 10P, 10G55, 10G, 50P, 50G

REVISION DATE 12-11-86 DATE ISSUED: 6-30-90

#### **IDENTIFICATION AND EMERGENCY INFORM**

PRODUCT NAME: PRODUCT #:

Air Tool Lubricant B4D001C

CHEMICAL NAME: CAS #'S:

Petroleum-based lubricating oil Mixture

PRODUCT APPEARANCE AND ODOR: CHEMICAL FAMILY:

Amber liquid, petroleum odor Petroleum hydrocarbon

SYNONYMS: EMERGENCY TELEPHONE:

Air Tool Lubricants 212-883-4411

#### **COMPONENTS AND HAZARD INFORMATION**

COMPONENTS: W/W HAZARD DATA (TLV,LD50,LC50, ETC.):

Petroleum-based lubricating oil TOLV 5mg. /meter cubed

CAS #'s: 64742-65-0 or (as an oil mist)

64742-57-0 or

64742-62-7 or

64741-88-4

Proprietary additives N/A

#### **HAZARDOUS MATERIALS IDENTIFICATION SYSTEM (HMIS):**

Health Flammability Reactivity Basis

1 1 0 Recommended by Exxon

#### **TRANSPORTATION INFORMATION**

##### **TRANSPORTATION INCIDENT INFORMATION:**

ICC: Compound or lubricant. Metal cutting, drawing or drilling, Dry, liquid or paste NOI

#### **EMERGENCY FIRST AID**

##### **EYE CONTACT:**

If splashed into the eyes, flush with clear water for 15 minutes or until irritation subsides. If irritation persists, call a physician.

##### **SKIN CONTACT:**

In case of skin contact, remove contaminated clothing and wash skin thoroughly with soap and water.

##### **INHALATION:**

Vapor pressure is very low. Vapor inhalation under ambient conditions is normally not a problem. If overcome by vapor from hot product, immediately remove from exposure and call a physician. If breathing is irregular or has stopped, start resuscitation, administer oxygen if available. If overexposure to oil mist, remove from further exposure until excessive oil mist condition subsides.

**INGESTION:**

If ingested, call a physician immediately.

**PROTECTION AND PRECAUTIONS****VENTILATION:** (Always maintain below permissible exposure limits)

Use local exhaust to capture vapor, mist or fumes, if necessary. Provide greater than 60 feet per minute hood face velocity for confined spaces. Provide ventilation sufficient to prevent exceeding recommended exposure limit or buildup of explosive concentrations of vapor air.

**RESPIRATORY PROTECTION:** (Use only NIOSH approved equipment)

Normally not needed at ambient temperatures, use supplied air respiratory protected in confined or enclosed spaces, if needed. Use filter, dust fume, or mist respirator type under misting conditions. Use can or cartridge; gas or vapor respirator type under conditions exceeding TWA standard.

**PROTECTIVE GLOVES:**

Use chemical-resistant gloves, if needed, to avoid prolonged or repeated skin contact.

**EYE PROTECTION:**

Use splash goggles or face shield when eye contact may occur.

**OTHER PROTECTIVE EQUIPMENT:**

Use chemical-resistant apron or other impervious clothing, if needed, to avoid contaminating regular clothing, which could result in prolonged or repeated skin contact.

**WORK PRACTICES/ENGINEERING CONTROLS:**

Keep containers closed when not in use. Do not handle near heat, sparks, flame, or strong oxidants.

**PERSONAL HYGIENE:**

Minimize breathing vapor, mist or fumes. Avoid prolonged or repeated contact with skin. Remove contaminated clothing; Launder or dry-clean before reuse. Remove contaminated shoes and thoroughly clean before reuse; discard if oil-soaked. Cleanse skin thoroughly after contact, before breaks and meals, and at end of work period. Product is readily removed from skin by waterless hand cleaners followed by washing thoroughly with soap and water.

THE INFORMATION AND RECOMMENDATIONS CONTAINED HEREIN ARE, TO THE BEST OF THE SELLER'S KNOWLEDGE AND BELIEF, ACCURATE AND RELIABLE AS OF THE DATE ISSUED. THE SELLER DOES NOT WARRANT OR GUARANTEE THE ACCURACY OR RELIABILITY, AND THE SELLER SHALL NOT BE LIABLE FOR ANY LOSS OR DAMAGE ARISING OUT OF THE USE THEREOF. THE INFORMATION AND RECOMMENDATIONS ARE OFFERED FOR THE USER'S CONSIDERATION AND EXAMINATION, AND IT IS THE USER'S RESPONSIBILITY TO SATISFY ITSELF THAT THEY ARE SUITABLE AND COMPLETE FOR ITS PARTICULAR USE.

**PHYSICAL DATA:**

The following data are approximate or typical values and should not be used for precise design purposes.

**BOILING RANGE: VAPOR PRESSURE:**

Wide range <0.1 @ 38 deg. C/100 deg F

SPECIFIC GRAVITY (25 deg C/25 degC) VAPOR DENSITY (AIR = 1):

(WATER = 1) >8

<1.0

MOLECULAR WEIGHT: PRECENT VOLATILE BY VOLUME: Wide range Negligible  
EVAPORATION RATE @ 1 ATM & 25 deg C SOLUBILITY IN WATER @ 1 ATM & 25 deg C  
(77 deg F) (n-BUTYL ACETATAE = 1): (77 deg F): <1.0 Negligible  
POUR, CONCEALING OR MELTING POINT: FREEZING POINT:  
N/E N/E

#### REACTIVITY

This product is stable and will NOT react violently with water. Hazardous polymerization will not occur. Avoid contact with strong oxidants such as liquid chlorine, concentrated oxygen, sodium hypochlorite or calcium hypochlorite.

#### DECOMPOSITION PRODUCTS UNDER FIRE CONDITIONS:

Fumes smoke carbon monoxide and other decomposition products, in case of incomplete combustion.

#### CONDITIONS TO AVOID:

Open flames.

#### TOXICITY

ORAL (Acute) LD 50 > 5 g/kg (total body weight)

DERMAL (Acute) LD 50 > 3.16 G/KG (total body weight)

EYE N/E

INHALATION (Acute) N/E

CHRONIC, SUBCHRONIC, ETC. N/E

This product does NOT contain any ingredients listed on IRAC, NTP, or the OSHA Z List. This product is NOT carcinogenic.

#### **SPILL OR LEAK PROCEDURES**

##### STEPS TO BE TAKEN IN CASE MATERIALS IS RELEASED OR SPILLED:

Keep product out of sewers and watercourses by diking or impounding. Absorb with sand or inert material. Sweep or scoop up and remove. Prevent spread of spill. Advise authorities if product has entered or may enter sewers, watercourses or extensive land areas. Assure conformity with local regulations.

WASTE DISPOSAL METHOD: (Consult federal, state, or local authorities for proper disposal procedures.)

Assure conformity with applicable disposal regulations. Dispose of absorbed material at an approved waste site or facility.

#### FIRE AND EXPLOSION HAZARD INFORMATION

FLASH POINT (MINIMUM): AUTOIGNITION TEMPERATURE

160 deg C (320 deg F) Test Method: COC N/E

NATIONAL FIRE PROTECTION ASSOCIATION (NFPA) – HAZARD IDENTIFICATION:

Health Flammability Reactivity Basis

1 1 0 Recommended by Exxon

## **FLAMMABLE OR EXPLOSIVE LIMITS (approximate percent by volume in air):**

Estimated values: lower 1%

### **EXTINGUISHING MEDIA AND FIRE FIGHTING PROCEDURES:**

Foam, water spray (fog), dry chemical, carbon dioxide and vaporizing liquid type extinguishing agents may all be suitable for extinguishing fires involving this type of product, depending on size or potential size of fire and circumstances related to the situation. Plan fire protection and responses strategy through consultation with local fire protection authorities or appropriate specialists.

The following procedures for this type of product are based on the recommendation in the National Fire Protection Association's "Fire Protection Guide on Hazardous Materials", Eighth Edition (1984): Use water spray, dry chemical, foam, or carbon dioxide. Water or foam may cause frothing. Use water to keep fire-exposed containers cool. Water forth may be used to flush spills away from exposure. Minimize breathing gases; vapor fumes or decomposition products. Use supplied-air equipment for enclosed or confined spaces or as otherwise needed.

### **UNUSUAL FIRE AND EXPLOSION HAZARDS:**

N/A

### **"EMPTY" CONTAINER WARNING:**

Empty containers retain residue (liquid or vapor) and can be dangerous. DO NOT PRESSURIZE, WELD, CUT BRACE, SOLDER, DRILL, GRIND OR EXPOSE SUCH CONTAINERS TO HEAT, FLAME, SPARKS, OR OTHER SOURCES OF IGNITION; THEY MAY EXPLODE AND CAUSE INJURY OR DEATH. Do not attempt to clean since residue is difficult to remove. "Empty" drums should be completely drained, properly bunged, and returned to a drum reconditioner. All other containers should be disposed of in an environmentally safe manner and in accordance with government regulations. For work on tanks refer to Occupational Safety and Health Administration regulations, ANSIZ49.1, and other governmental and industrial references pertaining to cleaning, repairing, welding, or other contemplated operations.

## **HEALTH AND HAZARD INFORMATION**

### **EXPOSURE LIMIT FOR TOTAL PRODUCT: BASIS:**

5 mg/cubic meter for oil mist in air OSHA regulation 29 CRF

1910.1000

### **VARIABILITY AMOUNG INDIVIDUALS:**

Health studies have shown that many petroleum hydrocarbons and synthetic lubricants pose potential human health risks that vary from person to person. As a precaution, exposure to liquids vapors, mists, or fumes should be minimized.

### **EFFECTS OF OVEREXPOSURE (signs and symptoms of exposure):**

Prolonged or repeated skin contact with this product tends to remove skin oils possibly leading to irritation and dermatitis; however, based on human experience and available toxicological data, this product is judged to be neither a "corrosive" nor an "irritant" by OSHA criteria. Product contacting the eye may cause irritation. Product has a low order of acute oral and dermal toxicity, but minute amounts aspirated into the lungs during ingestion may cause mild to severe pulmonary injury and possibly death.